

# Model 2385-LR/PN

## Long Range Top Loading Arm

Part List		
Pos.	Description	Model
1	Style 30 Base Swivel Joint	2833-2815
2	Boom Assembly	
3	Style 70 Double Swivel Joint	2833-2815
4	Primary Arm	
5	Style 40 Final Swivel Joint	2833-2815
6	Pneumatically Operated Ball Valve	
7	Drop Tube	2359-BF
8	Spring Balancing Cylinder	05182
9	Pillow Block	4354
10	Air Logic Control Unit	
11	Open / Close Valve Push Buttons	
12	Lock Down Device	2429-4942
13	Handle	

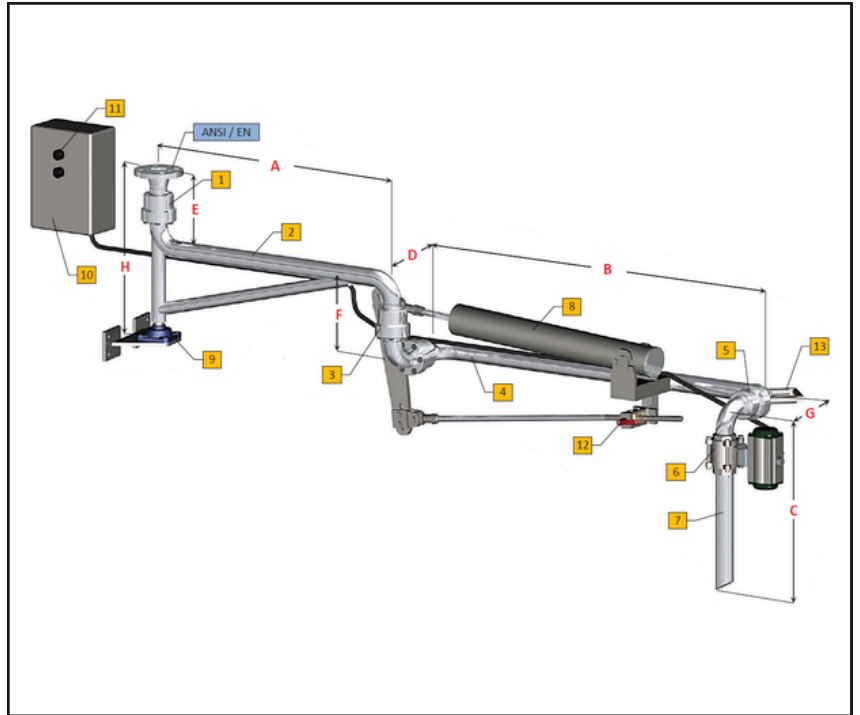

Standard Dimensions		
Dia	1.5"	3"
A	800÷1200	1500
B	1000÷1400	2000
C	500÷800	1600
D	244	285
E	249	273
F	244	285
G	244	285
H	500	600
Weight	80	100

### Operating Conditions

<b>Design Pressure</b>	10.0 Bar G
<b>Test Pressure</b>	15.0 Bar G
<b>Design Temperature</b>	-15°C / +65°C
<b>Seal Material</b>	PTFE
<b>Flow Rate</b>	1.5" – Up to 10 m <sup>3</sup> /h Max 2" – Up to 35 m <sup>3</sup> /h Max

### Options:

- Microswitch to signal the valve status (open/closed)
- Smoke suction system (with cover or cone and flanged flexible line)
- Overfill level sensor applied on the drop tube
- Locking device of the arm in parking position
- Standpost or base flange support bracket
- Check valve
- Non-destructive tests (RT-PT-MT) available on request

### Notes:

- This loading arm can also be supplied in complete stainless steel construction, realised with the Model 2833/SS Swivel Joints.

### Demonstration of Operating Area

