

# Marine Loading Arms

## Atlanta

### General Information:

The Atlanta Marine Loading Arm transfers liquid or gaseous products to and from ocean going or inland waterway tankers. This Marine Loading Arm features a separate support construction which is placed in balance through a cable pantograph system with 2 separate counterweights.

### Features:

- Model 4-2ST Swivel Joint (Sandwich Model)
- Separate support construction in carbon steel
- Product pipe in carbon steel or stainless steel
- Balance of inboard and outboard arm in each position by 2 separate counterweights through pantograph system
- Low maintenance, lightweight cable pantograph system
- Easy exchange of seals without dismantling loading arm and without auxiliary equipment
- Easy overhaul of complete swivel joint without the need of dismantling the loading arm and without auxiliary equipment
- Hydraulic operation
- Bridging of large operating range
- Limited dead weight
- The separate support construction guarantees overall same nominal bore through the complete loading arm
- Comes with separate ball bearings
- Hydraulic and mechanical locking of the arm in resting position
- Suitable for chemically aggressive products
- High and low temperature application
- High and low pressure application
- Dimensions: 6" - 16" (DN150 - DN400)

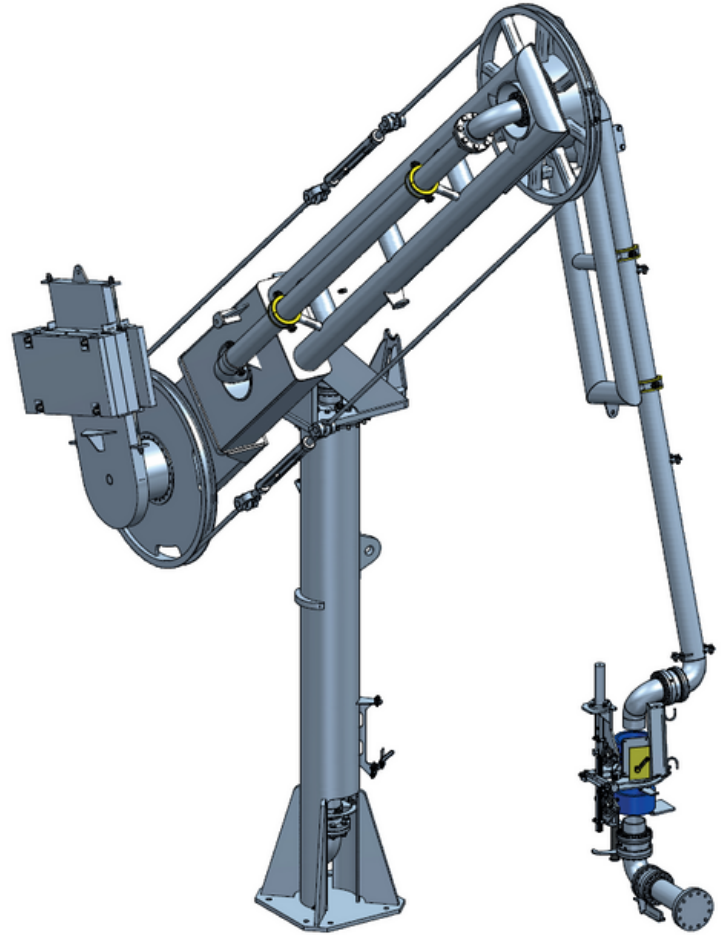

### Options:

- Hydraulic operation
- Manual/hydraulic QDC (Quick Connect-Disconnect Coupler)
- Manual/hydraulic shut off valve
- Insulation flange
- Vacuum breaker
- Purge/drain
- ERC (Emergency Release Coupler)
- Piggyback vapour return line
- Radio remote control
- Alarm range system
- Tracing and/or insulation
- Position monitoring system

