

Storage Tank and Reservoir Equipment

Floating Oil Skimmer

Standard Features:

In many processes there is an undesirable accumulation of two immiscible liquids (one water-based and one oil-based). These liquids can be separated in different ways, both physically and chemically, but mechanical separation is economical and does not alter the properties of the fluids.

The Floating oil skimmer (depending on the density of the fluid) is designed to extract one of the products (oil, water or both) without the need to purge to find out how much of each product is present.

It is designed to operate in tanks of various sizes, with all types of floating roofs and with components compatible with any stored product. The design is tailor-made for each individual case, ensuring a long, worry-free service life.

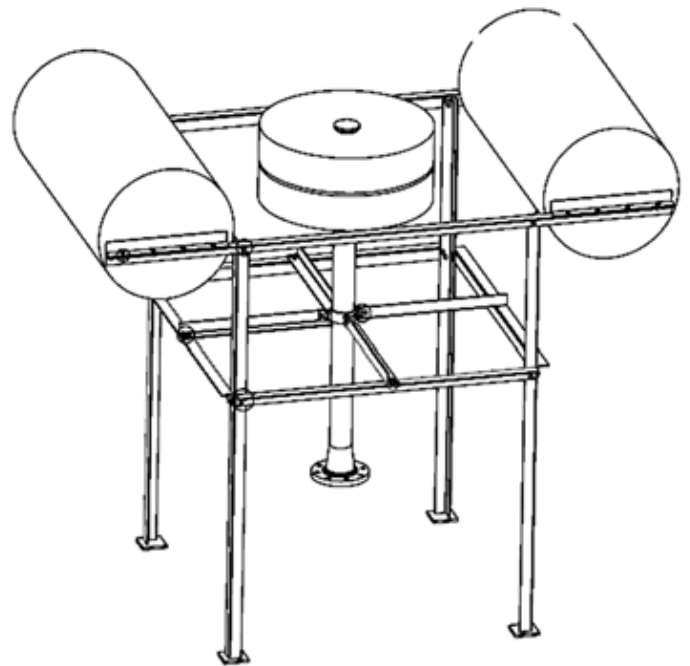

Materials:

- **Main Parts (Swivel Joint, Pipes, Supports):** Aluminium, Steel or Stainless Steel.
- **Floats:** Aluminium, Carbon Steel or Stainless Steel.
- **Seals:** FPM, FKM Viton, Buna or PTFE

