

Access Systems

Folding Stairs - Pneumatic

Designed for top loading tankers and platform access:

The EWFM Pneumatic Step Unit is suitable for all rail and road tanker loading and platform access, and is available in a range of standard sizes to suit many height variations.

Technical Specification:

All Units are manufactured and constructed to the highest quality for long lasting durability and many years of maintenance free operation in harsh environments.

Constructed from galvanised mild steel to BS 729 for long lasting durability in harsh environments.

All Units comply with ATEX 95 equipment directive 95/9/EC this concerns the supply and use of equipment in potentially explosive atmospheres.

Optional Extras:

An optional safety cage can be fitted to any pneumatic Step Unit which is constructed from galvanised mild steel to BS 729.

Support:

EWFM offer on-going staff training and instruction as well as annual inspection and maintenance contracts.

Delivery

Delivery is available on request - POA. Delivery is from our manufacturing site in Nottingham.

** Safety Cages are designed to individual needs

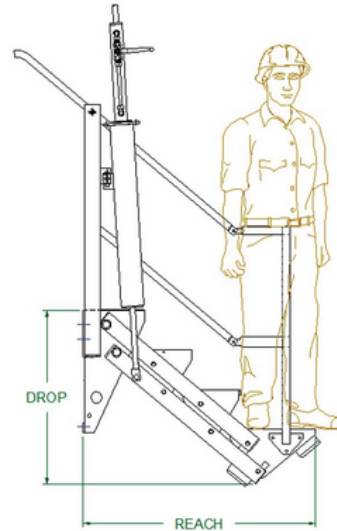

Pneumatic Folding Stairs

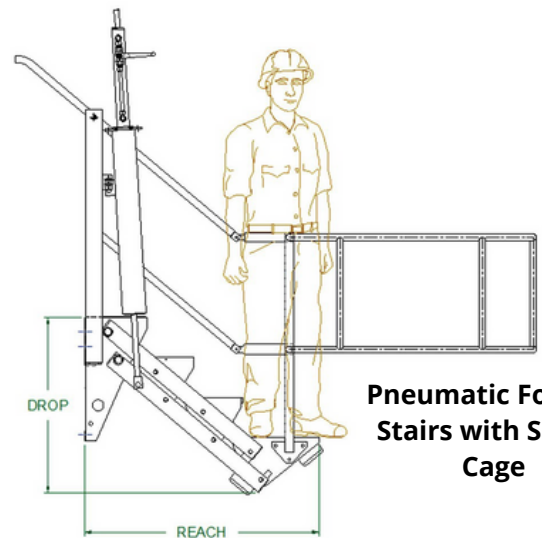

Pneumatic Folding Stairs with Safety Cage

Model	Unit Dimensions (mm)		Cage Dimensions (mm)			Step Width (mm)				Optional Extras
	Drop	Reach	Width	Length	Height**	800	1000	1200	1500	Cage
MK 2	481	685	1200	1200	550	Yes	Yes	Yes	X	Galv.
MK 3	677	919	1200	1200	550	Yes	Yes	Yes	X	Galv.
MK 4	874	1152	1200	1200	550	Yes	Yes	Yes	X	Galv.
MK 5	1070	1386	1200	1200	550	Yes	Yes	Yes	X	Galv.
MK 6	1280	1619	1200	1200	550	Yes	Yes	Yes	Yes	Al.
MK 7	1490	1853	1200	1200	550	Yes	Yes	Yes	Yes	Al.