

Model 750-LR

Long Range Bottom Loading and Vapour Recovery Arm with Vertical Flexible Hose

Part List		
Pos.	Description	Model
1	Heavy Duty Base Swivel Joint	2174-HD
2	Boom Assembly	
3	Style 70 Double Swivel Joint	2174
4	Tube Assembly	
5	Style 40 Additional Swivel Joint	2174
6	Flexible Hose with Safety Collars	
7	Style 30 Final Swivel Joint	2175
8	TTMA Flange	
9L	API Liquid Coupling / Dry Disconnect Coupling	3659
9RV	Vapor Recovery Coupling	3682
10	Spring Balancing Cylinder	05182
11	Manoeuvring Handle	
12	Additional Handle	

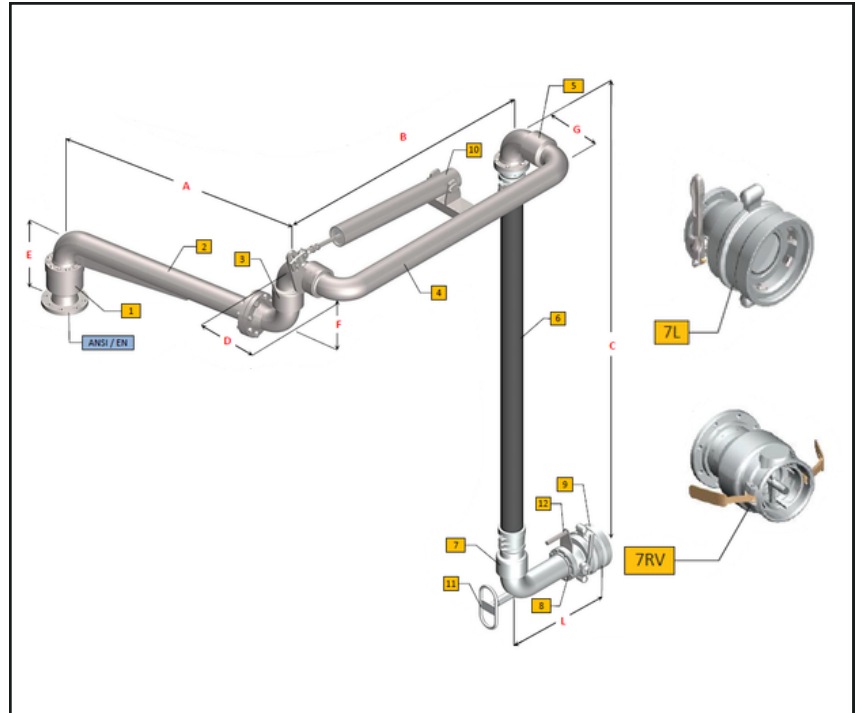

Standard Dimensions		
Dia	3"	4"
A	1200÷1500	1200÷1500
B	900÷1800	900÷1800
C	2500÷4000	2500÷4000
D	296	353
E	318	375
F	296	353
G	296	353
L	650	650
Weight	120	150

Options:

- Additional Swivel Joint (pos. 5) to provide more flexibility to the hose
- Model 4222 Safety Breakaway Coupling to prevent pull-away accidents
- Model 2141 Check Valve to interrupt the product flow after the pump stops
- Model 3659-CV Dry-Disconnect Coupling with integrated check valve
- Proximity switch to signal the coupling being connected
- Model 3784 Locking Device for the arm in parking position
- Model 2424 Sight Glass in proper position
- Model 4929 Support Standpost
- Non-destructive tests (RT-PT-MT) available on request
- (*) suitable for **BIO** or **Low-Temperature** products

Notes:

- Earthing continuity along the arm, according to the ATEX directive.

Operating Conditions

Design Pressure	10.0 Bar G
Test Pressure	15.0 Bar G
Design Temperature	-15°C / +65°C -40°C / +65°C
Seal Material	VITON® BUNA N Special VITON® (*)
Flow Rate	3"- 75 m³/h Max 4"- 125 m³/h Max

Demonstration of Operating Area

