

# Model 622-BC / 722-BC

## Fixed Range Top Loading Arm

Part List		
Pos.	Description	Model
1	Style 50 Double Swivel Joint	2174 / 2004 (*)
2	Loading Valve (Stay/Hold-Open)	504
3	Tube Assembly	
4	Drop Tube Swivel	536
5	Drop Tube with "T" Deflector	2359-T
6	Spring Balancing Cylinder	05182
7	Valve Remote Control	2356
8	3/8" NPT Vacuum Breaker	2336
9	Drip Bucket	2408

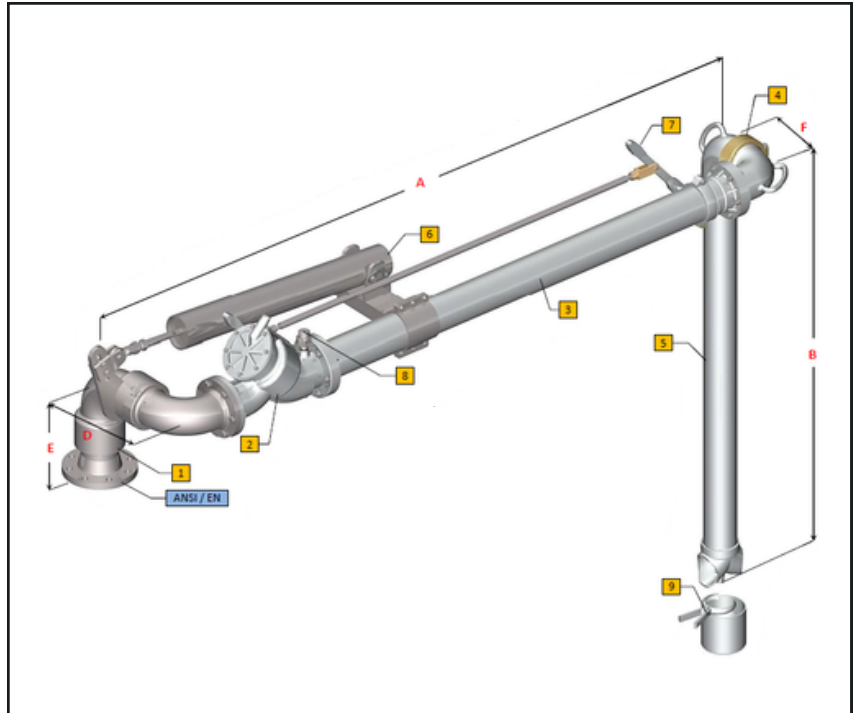

Standard Dimensions			
Dia	3"	4"	6"
A	2000÷3000	2000÷3000	2000÷3000
B	1200÷2000	1200÷2000	1200÷2000
C	/	/	/
D	296	353	525
E	289	328	462
F	174	201	278
Weight	85	105	200

### Operating Conditions

<b>Design Pressure</b>	10.0 Bar G
<b>Test Pressure</b>	15.0 Bar G
<b>Design Temperature</b>	-15°C / +65°C
<b>Seal Material</b>	VITON® BUNA N Special VITON® (**)
<b>Flow Rate</b>	3" – 75 m <sup>3</sup> /h Max 4" – 125 m <sup>3</sup> /h Max 6" – 280 m <sup>3</sup> /h Max

### Options:

- Pos. 5 with "flute beak" end (2359-BF)
- Pos. 5 with flow deflector (2359-D)
- Microswitch to signal the valve status (open/closed)
- Non-destructive tests (RT-PT-MT) available on request
- (\*\*) suitable for **BIO** products

### Notes:

- Earthing continuity along the arm, according to the ATEX directive.
- (\*) Model 2174 Swivel Joints installed on Model **622-BC** Top Loading Arms.
- (\*) Model 2004 Swivel Joints installed on Model **722-BC** Top Loading Arms.

### Demonstration of Operating Area

