

EWFM

Reduced Height Swivel Joint - Model 3996-WNE - Carbon Steel Standard Construction

Exploded View

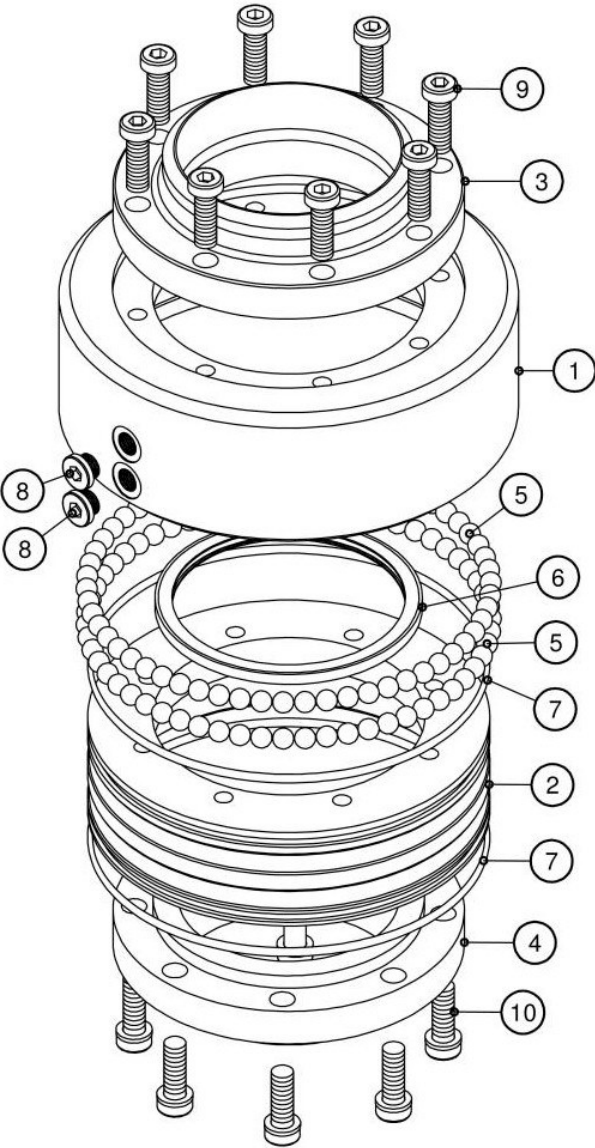

Standard Features:

The Model 3996-WNE reduced height carbon steel swivel joint with butt weld flanges is a 4 piece design with hardened and grinded raceways. The reduced height makes this swivel suitable for bottom unloading and it has a AISI 309 sealing surface. The design has PTFE® energized seals and it allows for easy swiveling, seal replacement and a quick swivel joint replacement.

Part List

Item	Description	Qty	Material
1	Flanged female	1	Carbon Steel
2	Flanged sleeve	1	Carbon Steel
3	Female Flange	1	Carbon Steel
4	Sleeve Flange	1	Carbon Steel
5	Balls		Carbon Steel
6	Energized Seal	1	PTFE filled+ELGILOY®
7	Grease O'Rings	2	BUNA N / Viton
8	Ball Plugs	2	AISI 303
9	Flange Screws	8	Carbon Steel
10	Flange Screws	8	Carbon Steel

Assembled View

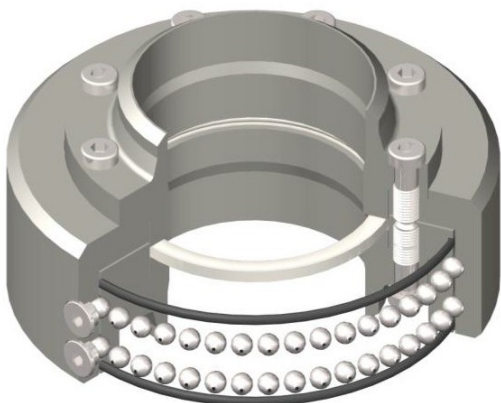

Primary Dimensions

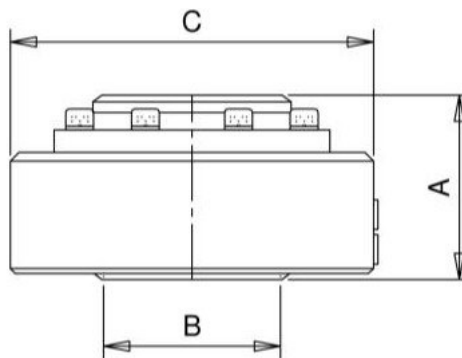

Size	A	B	C	Kg	Design Pressure
3"	93	78	186	8	10 Bar G
4"	106	102	208	13.7	10 Bar G