

Model 2879-JACK

Long Range Jacketed Top Loading Arm

Part List		
Pos.	Description	Model
1	Style 30 Jacketed Double Base Swivel Joint	2833
2	Boom Assembly (Liquid Line + Jacket)	
3	Style 70 Jacketed Double Swivel Joint	2833
4	Jacketed Ball Valve with Gear Operator	
5	Primary Arm (Liquid Line + Jacket)	
6	Style 40 Jacketed Final Swivel Joint	2833
7	Drop Tube with Standard End	2359-BF
8	Spring Balancing Cylinder	05182
9	Smoke Suction Cover (Optional)	
10	Suction Line (Optional)	
11	Level Sensor	
12	Self-Closing Vacuum Breaker	4772- $\frac{3}{4}$ "
13	Lock Down Device	2429
14	Handwheel Valve Remote Control	
15	Pillow Block	C-4354
16	Steam Hoses (Inlet and Outlet)	
17	Drip Bucket	2410
18	Handle	

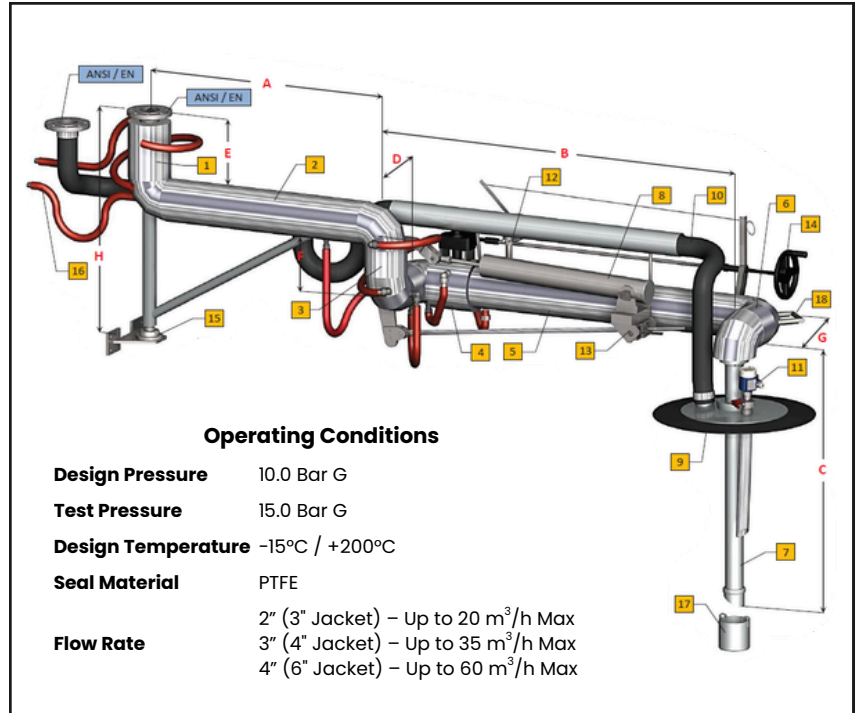

Options:

- Smoke suction system (with cover or cone and flanged flexible line)
- Level sensor applied on the drop tube (pneumatic or electronic)
- Pneumatic control for the vertical movement
- Pneumatically-operated loading valve
- Pneumatically-operated vacuum breaker
- Insulation up to the final swivel joint
- Locking device for the arm in parking position
- Base flange support bracket
- Non-destructive tests (RT-PT-MT) available on request

Standard Dimensions			
Dia	2" x 3"	3" x 4"	4" x 6"
A	1000÷1500	1000÷1500	1000÷1500
B	1500÷2000	1500÷2000	1500÷2000
C	1200÷1600	1200÷1600	1200÷1600
D	312	375	524
E	300	400	550
F	312	375	524
G	378	454	615
H	700	800	1000
Weight	300	400	520

Notes:

- Earthing continuity along the arm, according to the ATEX directive.

Demonstration of Operating Area

