

Model 2874

Closed System Bottom Loading Station

Part List		
Pos.	Description	Model
1	Style 30 Base Swivel Joint	2174
2	Boom Assembly	
3	Style 70 Double Swivel Joint	2174
4	Primary Arm	
5	Style 70 Double Swivel Joint	2174
6	Ball Valve with Locking Device	
7	Safety Breakaway Coupling	
8	Final Loose Flange	
9	Spring Balancing Cylinder	05182
10	Pillow Block	
11	Drain Valve	
12	Flanged Drain Flexible Hose	(*)
13	Gas Spring Balancer	
14	Handle	
15	Locking Device in Parking Position	
16	Style 30 Base Swivel Joint	2174
17	Boom Assembly	
18	Style 70 Double Swivel Joint	2174
19	Primary Arm	
20	Style 70 Double Swivel Joint	2174
21	Ball Valve with Locking Device	
22	Safety Breakaway Coupling	
23	Final Loose Flange	
24	Spring Balancing Cylinder	05182
25	Pillow Block	
26	Drain Valve	
27	Flanged Drain Flexible Hose	(*)
28	Gas Spring Balancer	
29	Handle	
31	Locking Device in Parking Position	
32	Support Stand Post	(**)

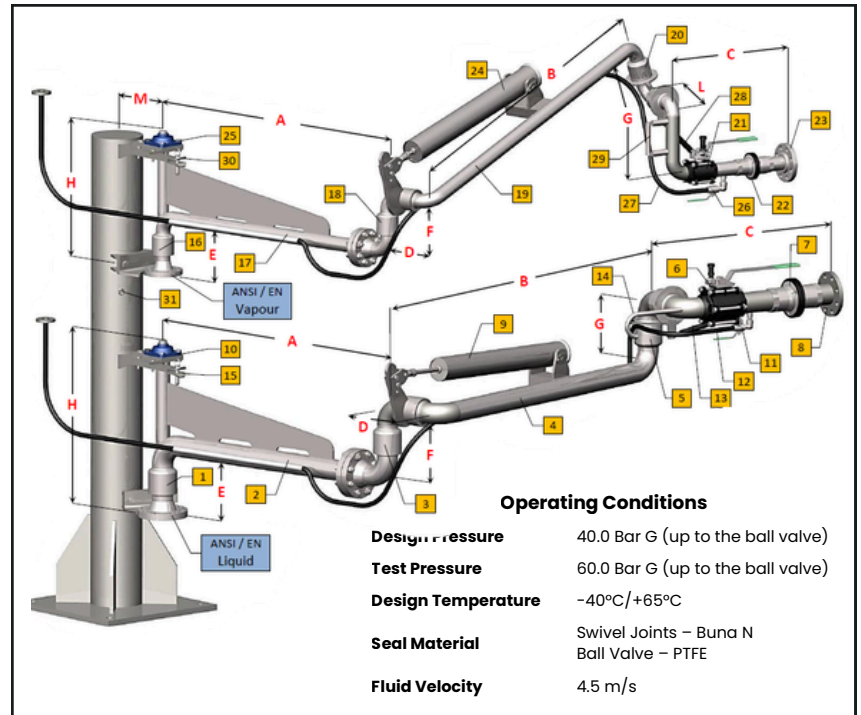

Options:

- Hammer union or dry gas coupling (pos. 8/23)
- Drain valve (pos. 11/26) with "dead man" function
- Non-destructive tests (RT-PT-MT) available on request

Notes:

- Earthing continuity along the arm, according to the ATEX directive.
- (*) equipped with protective tube along the straight parts of the arm
- (**) A support fixing plate suitable for the installation of the loading arms on a wall or on the gantry structures can be foreseen instead.

Standard Dimensions		
Dia	2" x 1.5"	3" x 2"
A	1500	1500
B	1800	1800
C	600	650
D	221	221
E	218	218
F	221	221
G	233	221
H	600	600
L	233	221
M	300	300
Weight	100	110