

Model 2504-BC

Triple Range Top Un/Loading Arm

Part List		
Pos.	Description	Model
1	Style 30 Base Swivel Joint	2833 / SS-2815-3885
2	Boom Assembly	
3	Style 70 Double Swivel Joint	2833 / SS-2815-3885
4	Primary Arm	
5	Style 70 Double Swivel Joint	2833 / SS-2815-3885
6	Manual Ball Valve with Locking Device	
7	Safety Breakaway Coupling	
8	Final Loose Flange	
9	Spring Balancing Cylinder	05182
10	Pillow Block	4354
11	Drain Valve with Flanged Flexible Hose	
12	Nitrogen Purge Valve	
13	Handle	

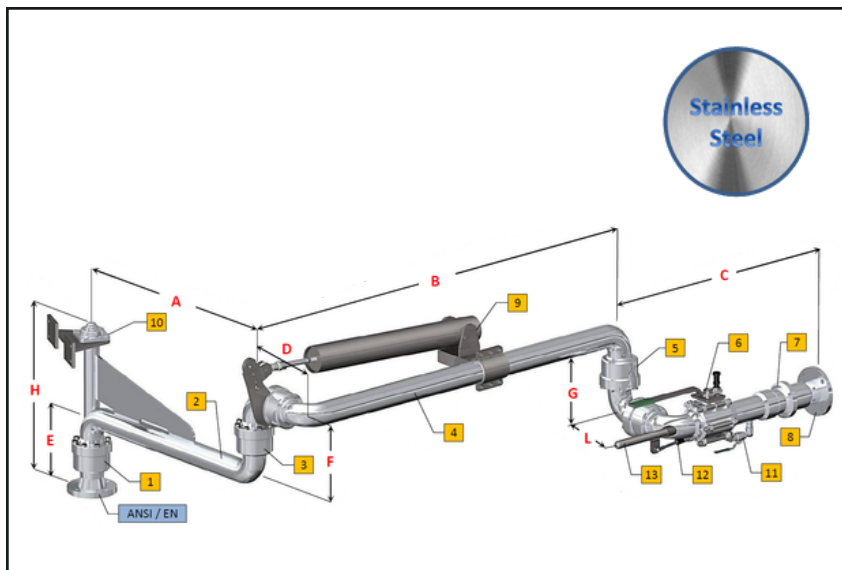

Notes:

- Earthing continuity along the arm, according to the ATEX directive.
- Model 2833/SS Swivel Joints made entirely from AISI 316-L stainless steel.
- Model 2815 Swivel Joints with AISI 316-L stainless steel internal parts and sealing surfaces and carbon steel external body.
- Model 3885 Swivel Joints made entirely from AISI 316-L stainless steel.

Operating Conditions

Design Pressure	10.0 Bar G
Test Pressure	15.0 Bar G
Design Temperature	-15°C / +65°C
Seal Material	PTFE
Flow Rate	2"- Up to 35 m ³ /h Max 3"- Up to 75 m ³ /h Max 4"- Up to 125 m ³ /h Max

Demonstration of Operating Area

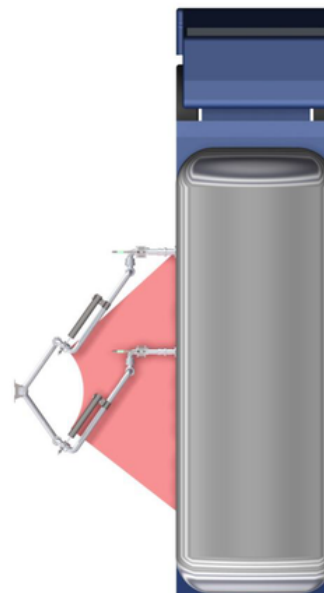

Standard Dimensions			
Dia	2" x 2"	3" x 3"	4" x 4"
A	1500	1500	1500
B	1800	1800	1800
C	600	750	800
D	285	309	373
E	273	303	348
F	285	309	373
G	285	309	373
H	600	650	700
L	285	309	373
Weight	120	160	230

Options:

- Locking device for the arm in parking position
- Proximity switch to signal the arm in parking position
- Dry-disconnect coupling or quick hose unit coupler
- Base flange support bracket
- Non-destructive tests (RT-PT-MT) available on request