

Model 2454-TRC

Electrically Heated Double Range Bottom Unloading Arm for Rail Trucks

Part List		
Pos.	Description	Model
1	Style 40 Base Swivel Joint	2834
2	Boom Assembly	
3	Style 70 Double Swivel Joint	2834
4	Primary Arm	
5	Style 40 Final Swivel Joint	2834
6	Coupler for CIS Rail Tanks	4871
7	Spring Balancing Cylinder	4879
8	Ex-d for the Heating System	
9	Support Base Plate	
10	Handle	

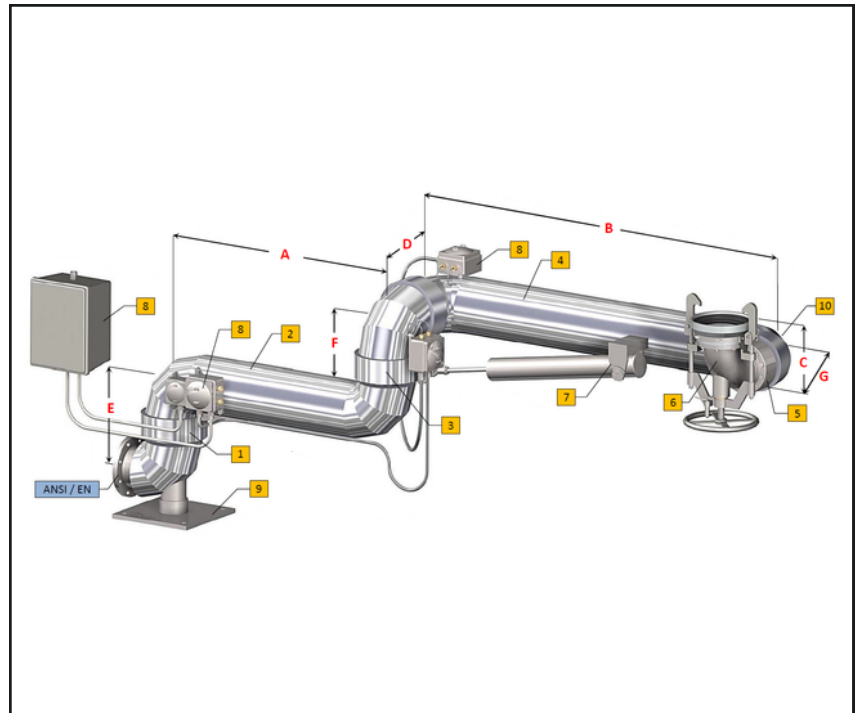

Standard Dimensions		
Dia	6"	8"
A	1000÷1500	1000÷1500
B	1500÷2500	1500÷2500
C	264	300
D	441	548
E	441	490
F	441	490
G	441	548
Weight	300	400

Operating Conditions

Design Pressure	1.0 Bar G
Test Pressure	1.5 Bar G
Design Temperature	-40°C/+200°C
Seal Material	PTFE

Demonstration of Operating Area

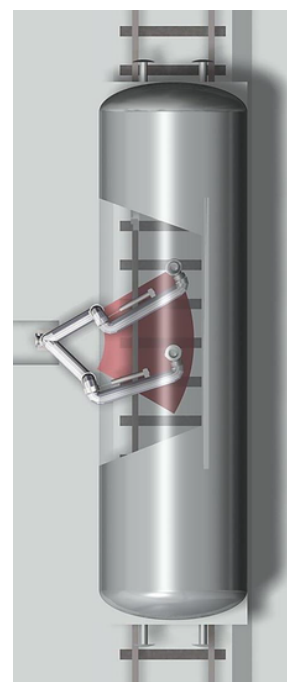

Options:

- Insulation up to the final swivel joint
- Locking device for the arm in parking position
- Support standpost with pillow block
- Non-destructive tests (RT-PT-MT) available on request

Notes:

- Earthing continuity along the arm, according to the ATEX directive.