

# Fixed Range Top Loading Arm for Food Service - Model 2385

## Operating Conditions

Design Pressure	10.0 Bar G
Test Pressure	15.0 Bar G
Design Temperature	-15°C / +65°C
Seal Material	PTFE (FDA Approved)
Flow Rate	2" - 35 mc/h Max 3" - 75 mc/h Max 4" - 125 mc/h Max

## Standard Dimensions

Dn.	2"	3"	4"
<b>A</b>	1800/2500	1800/2500	1800/2500
<b>B</b>	1600	1600	1600
<b>C</b>	207	279	343
<b>D</b>	285	309	373
<b>E</b>	273	303	348
<b>Weight</b>	80	120	170

## Demonstration of operating area

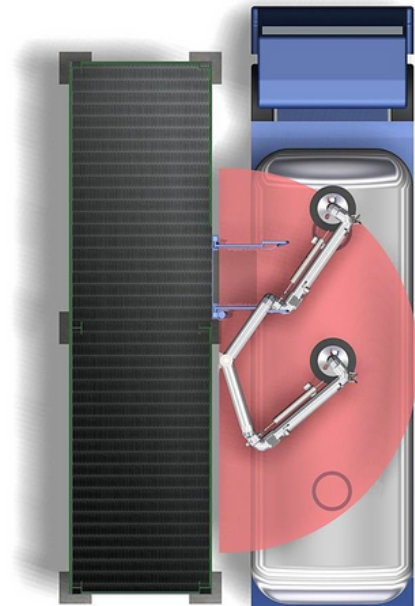

## Notes:

- Earthing continuity along the arm, according to ATEX directive
- Model 2833/SS swivels AISI 316-L total construction
- Model 3885 swivels AISI 316-L total construction
- Model 2815 swivels with AISI 316-L internal parts and sealing surfaces and carbon steel supporting parts

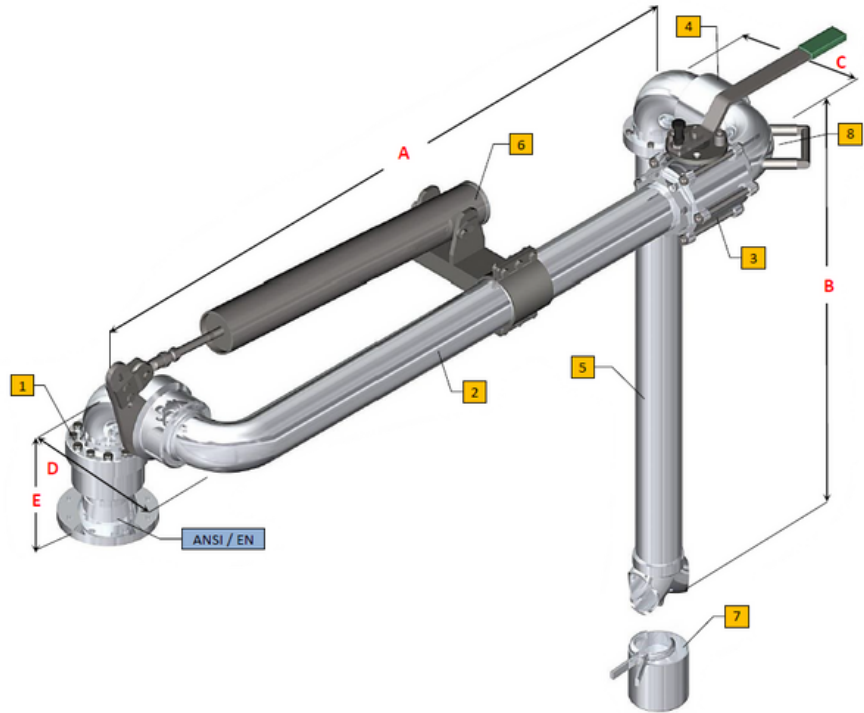

N.	Description	Dwg/Mod
1	Style 50 Double Swivel Joint	2833/SS-2815-3885
2	Primary Arm	-
3	Fire Safe (Full Bore) Ball Valve	-
4	Style 40 Drop Tube Swivel Joint	2175-2833/SS-2815-3885
5	Drop Tube with "T" Deflector	2359-T
6	Spring Balancing Cylinder	05182
7	Nipper Drip Bucket	2408
8	Handle	-

## Options:

- Pos.5 with flute beak end (2359-BF)
- Microswitch to signal valve opened/closed
- Ball valve installed at the beginning of the primary arm, with remote control and vacuum breaker
- Overfill level sensor installed on positional spider
- Locking device arm turned in parking position
- Polished internal surfaces on request
- NDT test (RT-PT-MT) available on request