

Model 2902-TRC

Electrically Heated Long Range Top Loading Arm with Rigid Vapour Recovery Line

Part List		
Pos.	Description	Model
1	Style 40 Base Swivel Joint	2833
2	Boom Assembly	
3	Style 70 Double Swivel Joint	2833
4	Primary Arm	
5	Style 40 Final Swivel Joint	2833
6	Vertical Drop Tube	
7	Spring Balancing Cylinder	05182
8	Smoke Suction Cone	
9	Up / Down Pneumatic Cylinder	
10	Level Sensor	
11	Air Logic Control Unit	
12	Up / Down Apex Push Buttons	
13	Up / Down Base Push Buttons	
14	Pneumatical Ball Valve	
15	Pneumatic Vacuum Breaker	
16	Open / Close Valve Apex Push Buttons	
17	Ex-d Box for Heating System	
18	Style 40 Base Swivel Joint	2833
19	Boom Assembly	
20	Style 70 Double Swivel Joint	2833
21	Primary Arm	
22	Style 40 Final Swivel Joint	2833
23	Vertical Drop Tube	
24	Spring Balancing Cylinder	05182
25	Pneumatic Ball Valve	
26	Ex-d Box for Heating System	
27	Handle	
28	Drip Bucket	

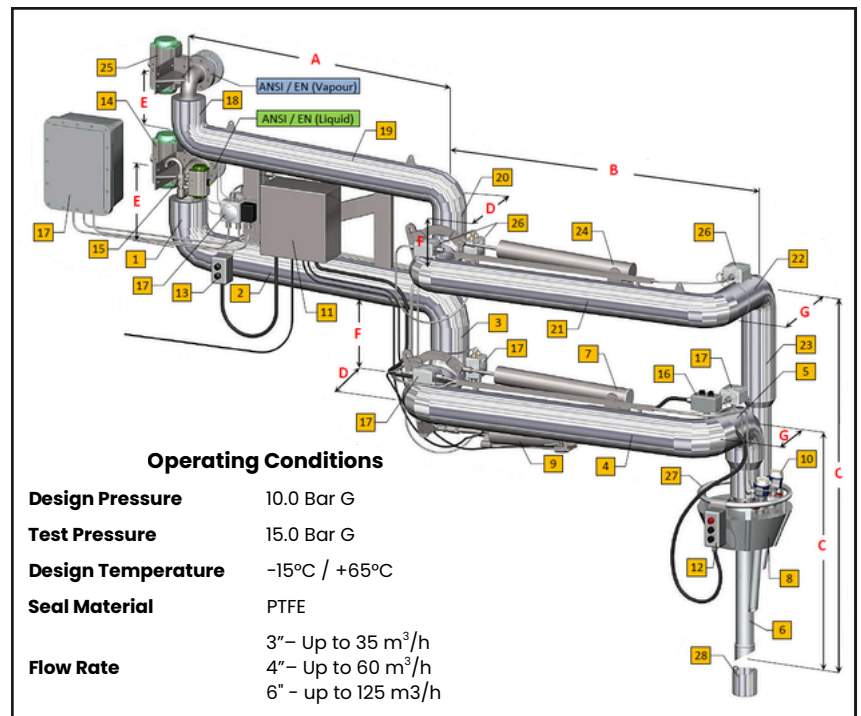

Options:

- 4928-A support standpost
- Locking device for the arm in parking position
- Double level sensor (pneumatic or electronic type)
- Insulation up to the final Swivel Joint
- Non-destructive tests (RT-PT-MT) available on request

Notes:

- Earthing continuity along the arm, according to the ATEX directive.

Demonstration of Operating Area

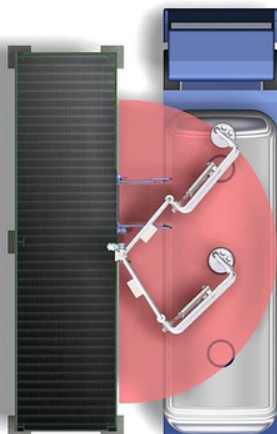

Standard Dimensions						
Dia	3" x 2"		4" x 3"		6" x 4"	
	L	V	L	V	L	V
A	1600	1600	1600	1600	1600	1600
B	1800	1800	1800	1800	1800	1800
C	1700	2500	1750	2550	1800	2600
D	350	285	426	312	600	375
E	305	273	350	305	460	350
F	350	285	426	312	600	375
G	312	427	375	441	524	520
H	550		600		650	
Weight	300		380		600	