

Model 3996 Swivel Joint

Carbon Steel Construction

Exploded View

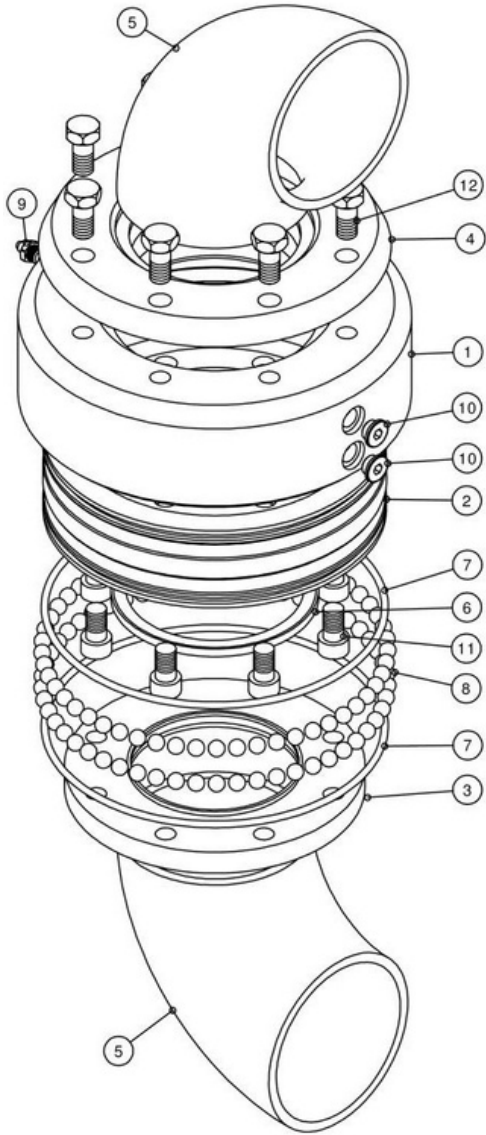

Assembled View

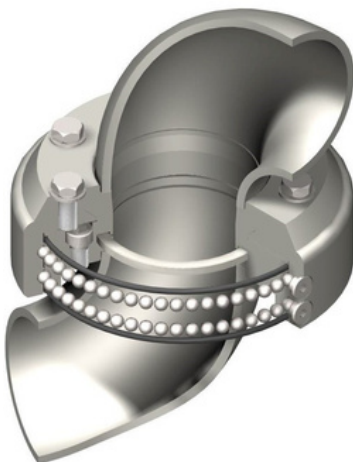

Standard Features:

The Model 3996 reduced height carbon steel Swivel Joint is a 4 piece design with hardened and ground raceways. The reduced height makes this swivel suitable for bottom unloading. The design has PTFE® energised seals and it allows for easy swivelling, seal replacement and a quick Swivel Joint replacement.

Part List

Item	Description	Quantity	Material
1	Flanged Female	1	Carbon Steel
2	Flanged Sleeve	1	Carbon Steel
3	Sleeve Flange	1	Carbon Steel
4	Female Flange	1	Carbon Steel
5	"Short Radius" Elbow	2	Carbon Steel
6	Primary Seal	1	PTFE filled + ELGILOY®
7	O'Ring	2	BUNA N / VITON
8	Balls		Carbon Steel
9	Grease Nipple	1	Carbon Steel
10	Ball Plugs	2	AISI 303
11	Flange Screws	8	Carbon Steel
12	Flange Screws	8	Carbon Steel

Primary Dimensions

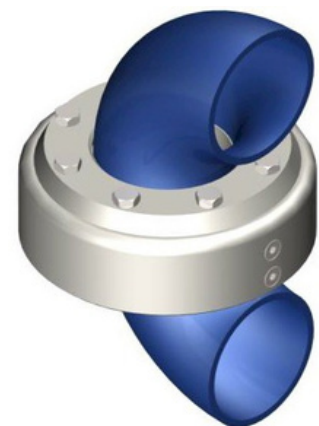
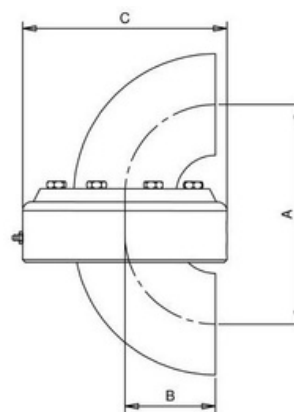

Size	A	B	C	Kg	Design Pressure
3"	200	76.2	206	13.7	10 Bar G
4"	245	101.6	224	15.2	10 Bar G
6"	385	152.4	340	40.3	10 Bar G
8"	496	203.2	400	57.5	10 Bar G