

# Storage Tank and Reservoir Equipment

## Articulated Drainage Unit for Floating Roof Tanks

### Standard Features:

The articulated drainage is installed inside floating roof storage tanks and has the function to drain the rainwater from the roof of the tank. The roof is designed with a slope converging on the centre where there is a collection point with connection flange for the drainage unit. The drainage unit installed inside the tank follows the vertical movement of the roof.

### Operating Conditions

Seal Material VITON

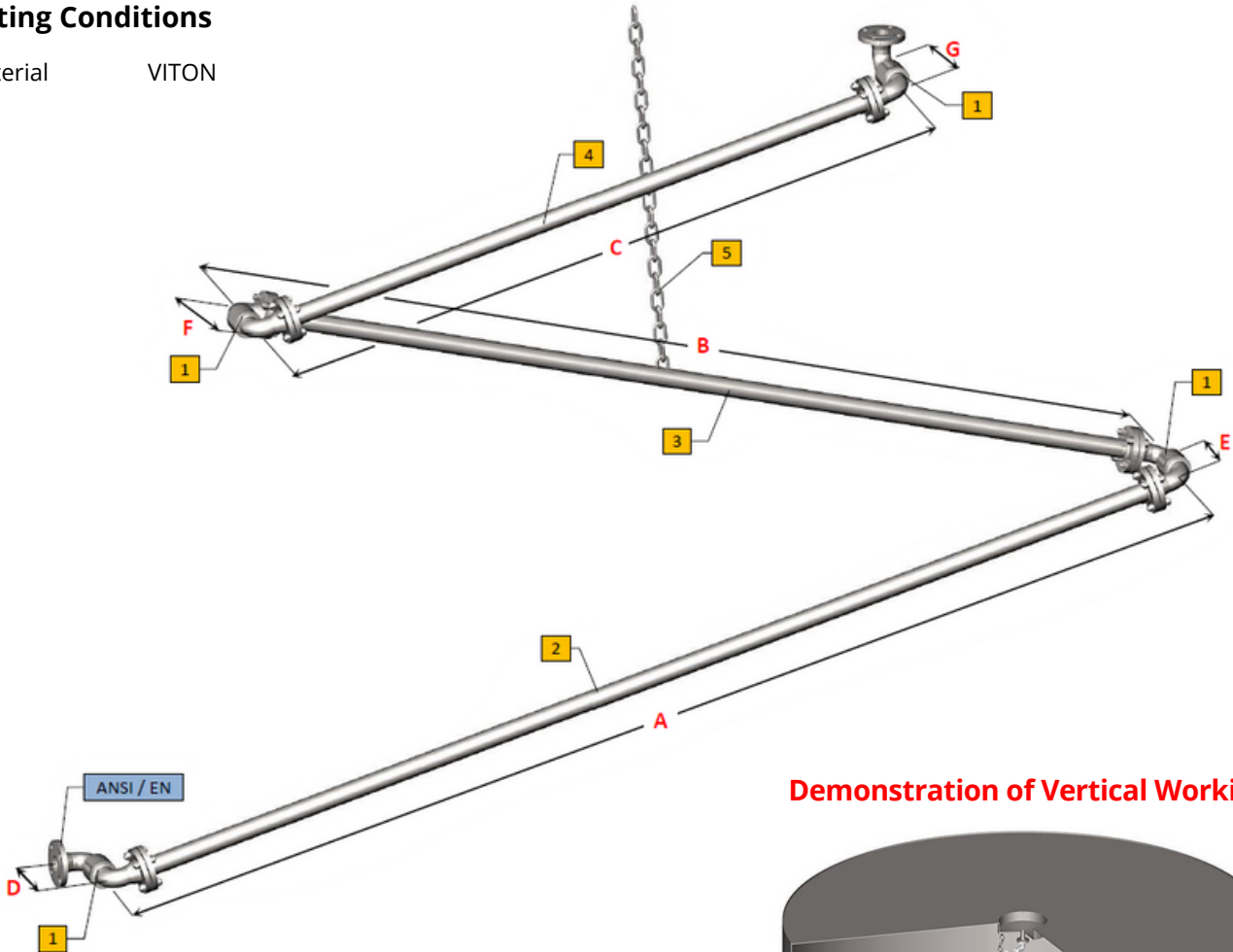

### Demonstration of Vertical Working

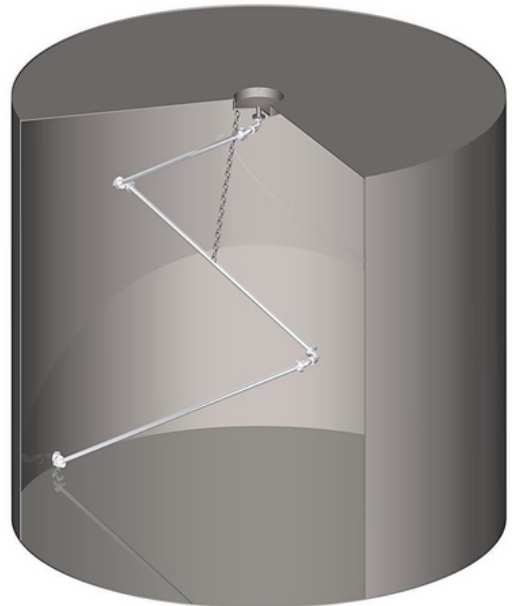

N.	Description	Dwg/Mod
1	Style 40 Swivel Joint	2174
2	Flanged Lower Section	-
3	Flanged Middle Section	-
4	Flanged Upper Section	-
5	Support Chain	-

### Notes:

- (\*\*) "A", "B" and "C" dimensions are calculated according to the tank height

Size	A	B	C	D	E	F	G
3"	**	**	**	296	296	296	296
4"	**	**	**	353	353	353	353