

# Filling & Emptying Equipment

## Model AZV® Delivery Nozzle

### Model AZV® FIXOMAT

### DN20 / 25 / 32 / 50 ( 1" / 1½" / 2" ) Automatic Delivery Nozzle

- Automatic shut-off when filling level is reached
- Secure shut-off even when under pressure variation from 0.7 to 6.0 bar
- Optimum filling level due to low foaming
- Gas recycling or vapour recovery models available (see below G1-G0).

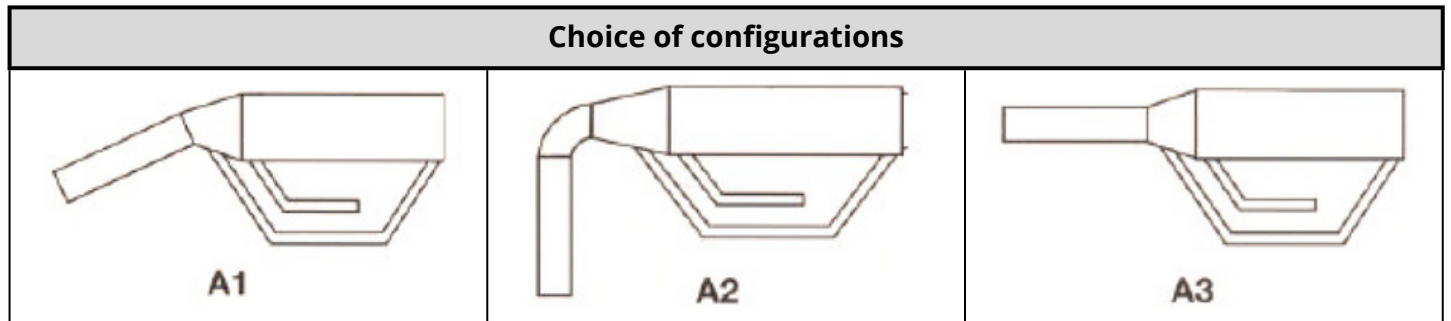
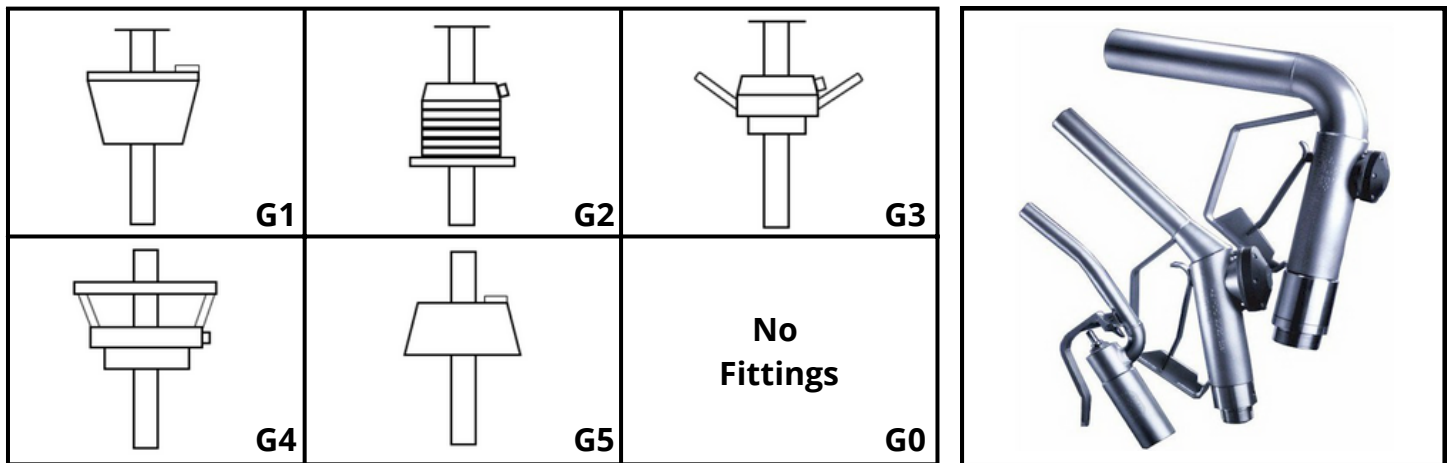

Technical Data	DN20/25-G1" AG	DN32-G1 1/2" AG	DN50-G2" AG
Flow Performance	90 l / min	200 l / min	400 l / min
Operation Pressure - B1 B2	1-3.0 bar	1-3.0 bar	1-6.0 bar
	1-6.0 bar	1-6.0 bar	/
Nominal Pressure	10.0 bar	10.0 bar	10.0 bar
Weight	1.8 kg	2.3 kg	2.8 kg
Total Length	390 mm	465 mm	400 mm
Spout Diameter	28 mm	40 mm	60 mm
Spout Length	180 mm	200 mm	275 mm
Inlet Swivel	Available on request	Available on request	Included